

Subaru Impreza WRX, Liberty/Legacy (Turbo), Forester GT Clutch Removal & Replacement

Ref: TNO

Issue date: 13 Dec 2004

Issue number: 2

Subaru Impreza WRX / Liberty & Forester GT How to R & R Turbo Pull Type Clutch

The Pull Type Clutch fitted to the above mentioned vehicles includes a thrust bearing which locks into the diaphragm of the clutch cover assembly. The thrust bearing must be disengaged from the release fork assembly before the gearbox can be removed.

Gearbox Removal:

View of left hand side of gearbox. (Fig. 1)
Remove parts as necessary to access and then remove starter motor. Behind where the starter motor fits on the upper side of the bellhousing there is a round threaded plug approximately 25mm in diameter, with a hexagonal recess in the face to accept a 10mm allen key. (Fig. 2)

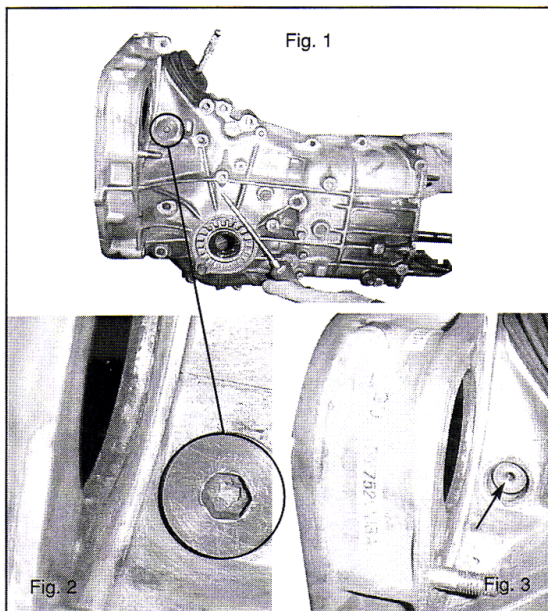

Remove this plug and inside there is a cross shaft approximately 20mm in diameter which

secures the release fork. (Fig. 3) This shaft is threaded to accept a 6mm bolt, 50-60mm in length. (Fig. 4)

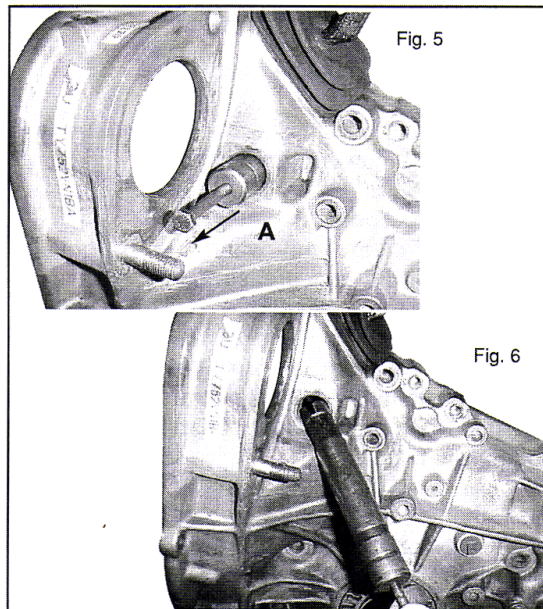
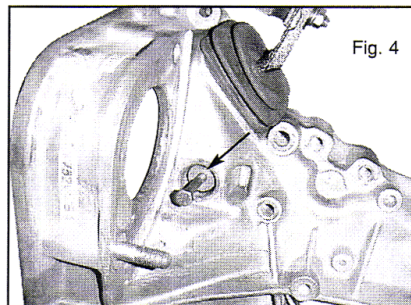

Insert the bolt, and pull on the bolt [A] which enables the shaft to be withdrawn completely. (Fig. 5 & 6)

Subaru Impreza WRX, Liberty/Legacy (Turbo), Forester GT Clutch Removal & Replacement

Ref: TNO

Issue date: 13 Dec 2004

Issue number: 2

This allows the fork to be lifted up and moved back to disengage the release bearing. (Fig. 7, 8 & 9)

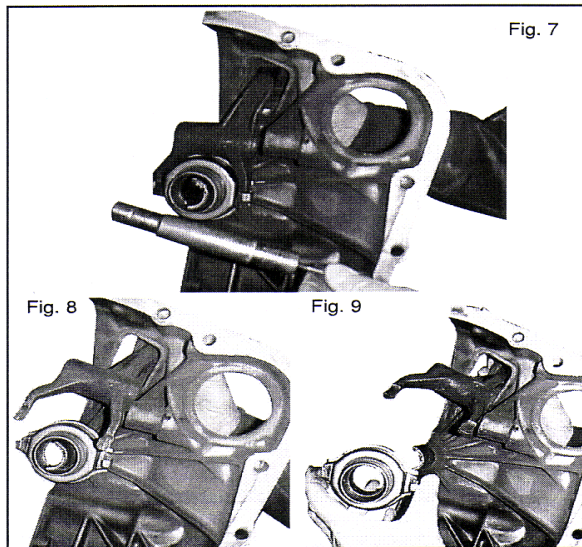

The gearbox can now be removed.

Remove clutch from flywheel and resurface flywheel. Fit a new spigot bearing.

Re fitting gearbox:

Thoroughly clean and wash the bellhousing removing all dirt and grease, lightly grease the fork tips and thrust bearing.

Leave the 2 lower studs which hold the bellhousing to the block, out until last. This enables easier installation. Ensure the 2 studs are cleaned thoroughly which enables refitting of these with fingers.

Bolt the clutch to the flywheel, **fit the new release bearing to the fork**, refit fork assembly and check for smooth operation. Push the fork so the release bearing is at the back of the bellhousing (**don't assemble the bearing onto the cover assembly**). Refit gearbox and when all is secured, push the fork sharply in the opposite direction to which it normally operates and the release bearing will lock into the diaphragm of the cover assembly.

Before bolting back the slave cylinder, it is

advisable to gravity bleed the system for any signs of air. Once bolted into place, the bleeder nipple is difficult to access and the slave cylinder is on an angle with the bleeder nipple at a low point, which makes it difficult to expel any trapped air.

Adjustment is available at the master cylinder. Back off a couple of turns towards the pedal, **not towards the master cylinder**. Test and repeat if necessary.

Important Note:

When repairing Subaru WRX / Liberty models, should the bearing be "accidentally" fitted to the diaphragm of the cover assembly it is removed with a screwdriver the same as other vehicle makes.

After ensuring the thrust bearing is pushed firmly towards the diaphragm and retainer plate assembly, insert a screwdriver blade between the back of the thrust bearing body and the plate of the retainer assembly nearest the bearing body. (Fig. 10)

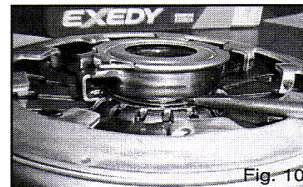

Twist the screwdriver 90 degrees and the bearing will be released. (Fig. 11) This action opens the snap ring in the retainer assembly which secures the bearing.

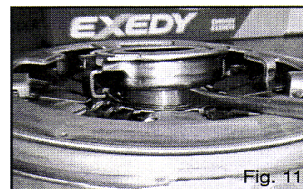

Exedy Pty Ltd Australia thanks DMA Motorsport Preparations of Clayton in Victoria for their assistance in providing the sectional gearbox.